



### **Requirements for Applying for May 2025 Exams**

**Candidates who wish to appear in the May 2025 Exams are advised to check their status at the Self-Service Portal (SSP) and be assured that they meet the eligibility criteria to be able to effortlessly fill the exam forms at SSP.**

#### **Before filling the exam form please check the following:**

1. Candidates are required to have valid login credentials on SSP. If not, please visit <https://eservices.icai.org/> to create the login.
2. Candidates are required to have valid course registration. In case of lapsed course registration, please make sure to convert on SSP.

**Conversion:** Candidate whose course code in their dashboard is not as under need to convert to new course before applying for **May 2025 Exam**. No fees is required to be paid

Final: NEWFIN23 or CONFIN23

For Conversion, use your login credentials of SSP and Go to Student Functions- -> Student Module --> Course Registration--> Apply for Conversion Convert Old to New Course

3. Candidates whose latest photograph and signature are not available or are not of acceptable quality to be printed on marksheets are required to upload/ change the same on the Self-Service Portal **before filling up the exam form. The photograph/signatures must be as per the details given under "Photo Requirements" and "Signature Requirements" in this announcement.**
4. Candidates whose articleship status (final) is in pending mode i.e. **other than Registered** (Registered inactive, Requested, Terminated, Requested for Termination, Approved by Member, Submitted, Asked for Correction, Saved, On Hold, Awaiting Competent Authority Approval, Rejected, Rejected by Member, rejected by RO) are required to get their Articleship Training Deed status updated on SSP as '**Registered**'). For Articleship Status, use your login credentials of SSP and Go to Article Functions--> Articleship/Audit--> Articleship--> Articleship Application (Form 102/103). **For any clarification, contact at e mail ids/phone nos. at <https://resource.cdn.icai.org/29576contact-sro19221.pdf>**
5. For any other correction required please raise a ticket in SSP or send mail to  
Final: final\_examhelpline@icai.in

**Detailed Eligibility conditions for May 2025 Final exams are as below. The candidates are advised to check that the data on SSP is updated to meet these additional requirements.**

**Final Course**

**A. Candidates should have registered/Converted for Final New Course.**

**B. Article Training:**

The candidate must have completed prescribed period of 3 years or 3½ years, as the case may be, of articulated training as on the date of filling the exam application form

Or,

The candidate must be due to complete the prescribed period of 3 years or 3½ years, as the case may be, of articulated training including excess leave, if any, on or before 30<sup>th</sup> April 2025,

Or,

The candidate must be in service as on 01st May 2025 and serving the last twelve months of articulated training including excess leave, if any, and due to complete 3 years on or before 30<sup>th</sup> April 2026. (for PE-II stream student and PE-II stream students converted to IPCC/IIPCC),

Or,

The candidate must be in service as on 01st May 2025 and serving the last six months of articulated training including excess leave, if any, and due to complete 3½ years on or before 31<sup>st</sup> October 2025 (for PCC stream student),

Or,

The candidate must be in service as on 01st May 2025 and serving the last six months of training including excess leave, if any, and due to complete 3 years on or before 31<sup>st</sup> October 2025. (for Intermediate/IPCC/IIPCE student).

Or,

The candidate must be in service as on 01st May 2025 and serving the last twelve months of training including excess leave, if any, and due to complete 3½ years articleship on or before 30<sup>th</sup> April 2026. (for students converted from PE-II to PCC as well as students converted from PE-II to PCC and then to IPCC/IIPCE)

**Candidates who have taken termination are advised to re-register for the balance period of training so as to be in service as on 01st May 2025 and due to be complete 3 years or 3½ years of training, as applicable (including excess leave taken, if any) on or before 31<sup>st</sup> October 2025 or 30<sup>th</sup> April, 2026 as the case maybe.**

**C. Advanced Integrated Course on Information Technology and Soft Skills (AICITSS):**

In terms of Regulation 29D(1)(iii) read with 51E/72E of the CA Regulations 1988, students under the New Scheme of Education and Training ( implemented with effect from 1st July 2023) are required to complete the Advanced Integrated Course on Information Technology and Soft Skills (Advanced ICITSS) successfully for being eligible to appear in the Final Examination held under the syllabus approved by the Council under Regulation 31(v) of the CA Regulations 1988, the next examination of which is to be held in May 2025.

In other words, the students should have completed Advanced ICITSS on or before 10<sup>th</sup> April 2025 to be eligible to appear in May 2025 examinations. Candidates who have not yet passed the AICITSS – IT Test are advised to visit <https://resource.cdn.icai.org/82794exam66866.pdf> to know the schedule of AICITSS– IT Test and clear the test to be eligible for Final May 2025 exams.

Advanced ICITSS is a combination of Management & Communication Skills and Advanced IT Course, which is effective from 1st July 2023 with the implementation of New Scheme of Education and Training. Candidates are required to undergo the Advanced ICITSS Advanced IT test, conducted by the Exam Dept. of ICAI, after completing the Advanced Information Technology component of the above-mentioned course.

Further, it is hereby clarified that students who have undergone only one, i.e. either GMCS II or Advanced ITT under the **Final (Old)** course have to undergo the remaining component, i.e. Advanced ICITSS (IT) or Advanced ICITSS(GMCS-II). They are not required to undergo Advanced ICITSS (IT and MCS) in its entirety.

Candidates who have converted from Final Old Course to Final New Course but appeared at least once in the Final (old) Examination earlier, are not required to Complete Advanced ICITSS before appearing in Final Examination to be held in May 2025 but in any case, they are required to complete the Advanced ICITSS course before applying for the membership of the Institute.

Candidates may also visit announcement dated 22-12-2023 by clicking following link: <https://www.icai.org/post/exam-announ-221223>

#### **D. SELF PACED ONLINE MODULES (SPOM)**

The Exam department of ICAI has launched Self-paced Module Test (SPMT) Portal <https://spmt.icai.org> for candidates who have completed prescribed learning hours for respective Self-Paced Online Module **SET A:** Corporate and Economic Laws and Module **SET B:** Strategic Cost & Performance Management. Details of eligibility of such candidates are as below:

- A)** The students who were admitted to the Final Examination till November 2023 are exempt from appearing in Self-Paced Online Module Tests Set C and Set D. **However, it is mandatory for them to qualify Set A and Set B before applying for membership** as per below eligibility criteria:

<b>SL. NO.</b>	<b>STATUS OF APPEARANCE IN CA FINAL OLD COURSE EXAM</b>	<b>MODULES TO BE QUALIFIED</b>
i)	Appeared in Final Exam till November 2023 but could not pass either of the groups	<b>SET A AND SET B</b>
ii)	Passed group second till November 2023 but could not pass group first	<b>SET A only</b>
iii)	Passed group first till November 2023 but could not pass group second	<b>SET B only</b>
iv)	Exemption secured in Paper 5 in any of the attempts from May 2022 to November 2023 but could not pass either of the groups	<b>SET A only</b>
v)	Exemption secured in Paper 4 in any of the attempts from May 2022 to November 2023 but could not pass either of the groups	<b>SET B only</b>
vi)	Exemption secured in Paper 4 and Paper 5 in any of the attempts from May 2022 to November 2023 but could not pass either of the groups	<b>All Modules Exempt</b>

- B)** Students, other than those who are covered under (A) above, who were admitted to the Final Examination of **May 2024** are exempt from appearing in Self-Paced Online Module Tests Set C and Set D. **However, it is mandatory for such students to qualify Set A and Set B before applying for membership.**
- C)** Students, other than those covered under (A) & (B) above, who were admitted to the Final Examination of **November 2024** are **required to mandatorily qualify Set A, B, C and/or D as applicable on or before 10<sup>th</sup> April,2025.**
- D)** Intermediate candidates who had cleared both the groups of Intermediate Examinations till November 2023 and completed AICITSS Exam along with 2.5 years of article ship training, including excess leave, on or before 30<sup>th</sup> April 2025 are exempt from appearing in Self-Paced Online Module Test Set C & D. **However, it is mandatory to qualify SET A and Set B before applying for membership.**
- E)** Intermediate candidates who had cleared both the groups of Intermediate Examinations after November 2023 and completed AICITSS Exam along with 2.5 years of article ship training, including excess leave, on or before 30<sup>th</sup> April 2025 are **required to mandatorily qualify all the Modules (i.e., SET A, B, C & D) before appearing in the Final Examinations i.e., on/before 10<sup>th</sup> April 2025.**

**Or**

Intermediate students who had cleared either of the groups up to November 2023 or before and cleared the remaining Group under Unit Scheme from **May 2024 to January 2025** and completed AICITSS Exam along with 2.5 years of article ship training, including excess leave, on or before 30<sup>th</sup> April 2025 are **required to undergo and pass Self-Paced Online Modules before appearing in the Final Examinations i.e., on/before 10th April 2025 to become eligible for Final Examination to be held in May 2025** as per below eligibility criteria:

SL. NO.	Number OF PAPERS PASSED AT INTERMEDIATE LEVEL	MODULES TO BE QUALIFIED
i)	Passed 6 papers at Intermediate level	SET A, B, C, D
ii)	Passed 7 papers at Intermediate level	SET A, B and either of SET C or SET D
iii)	Passed 8 papers at Intermediate level	SET A and SET B

For any clarification relating to online registration/booking of slots of Self-Paced Online Module Tests, please mail to [exam\\_spmt@onlineregistration.org](mailto:exam_spmt@onlineregistration.org) or [spmt\\_examhelpline@icai.in](mailto:spmt_examhelpline@icai.in)

### **Photo Requirements**

The requirements of the photograph are:

- The photo should be **colored** or **black/white** with 80% face (without face mask) visible including ears against a white background.
- Must have a clear contrast of the image.
- Do not wear goggles and caps while taking a photo. However, they can wear spectacles.
- The background of the photograph must be in white and must be clearly visible.
- A straight-looking relaxed face should be there.
- If flash is used while taking the picture, then make sure that there is no “red eye”.
- No caps or goggles are allowed; however, religious headwear is allowed but it should not cover the

face.

- No selfies are allowed
- The photograph be scanned as jpg/jpeg having size 20-50 KB
- ***The scanned Photo should be well cropped so that there are no extra/white spaces, and the image is stored as jpg/jpeg***
- **Take care that the photo as described above fits in the size 4.5 cm by 3.5cm**

### **Signature Requirements**

The requirement of the scanned signature is:

- Signature should be done on a white sheet with a black pen.
- The file size of the image must be between 10-20 KB (clearly visible)
- ***The scanned signature should be well cropped so that there are no extra/white spaces, and the image is stored as jpg/jpeg***
- **Take care that the signature as described above fits in the size 6 cm by 2cm**

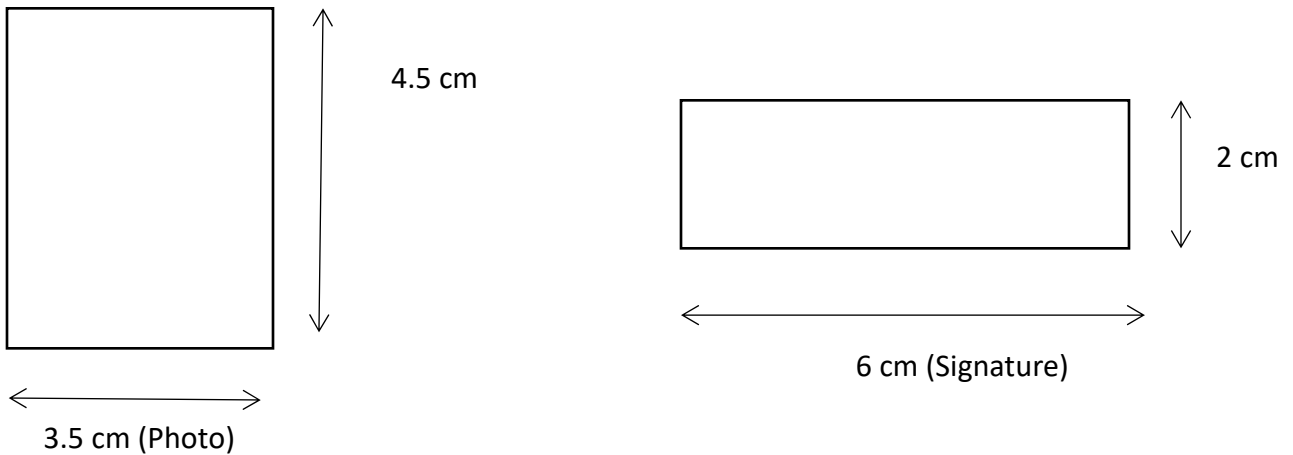

**EXAMINATION DEPARTMENT**